

The **Fumex-DT (desktop)** is a quiet, low cost, highly efficient fume extraction system designed to capture and filter the fumes generated in a variety of processes. Simple to use and operate the system incorporates intelligent controls, filter monitoring, variable speed airflow and easy interface / connectivity. The Fumex DT can be fitted with a standard 3 stage filter incorporating HEPA and Gas/Odor filtration or specialty application specific medias. The compact size and simplicity of design is ideal for the following applications.

Laser Engraving

Select Laser Sintering

Soldering | Hobbyists

3D Printing

Multi-Jet Modeling

Dental

Direct Digital Manufacturing

SLA

3DP



**Construction:**

- Cabinet: 16 ga. welded steel, powder coat finish
- Baffled – sound attenuated
- Sound Level: 55 dbA
- Weight: 25 lbs.

**Blower Motor:**

- Performance: 105 cfm
- Variable speed blower
- Centrifugal - direct-drive, brushless motor
- Rated 20,000 hour + mtbf

**Electrics/Controls:**

- 100-130/1/50-60 (120-volt plug)
- Digital display with variable speed blower
- Pre-wired 3 wire power cable, 9 ft. with plug
- Digital Controls
  - Electronic variable speed blower control
  - High visibility LED filter indicator
- Calibrated electronic VOC gas sensor
- Electronic digital interface relay for filter monitoring
- Amp Draw: 2.0 amps

**Standard Equipment:**

- Complete filter set
- 5 ft. 2-ply ribbed rubber hose
- 2" diameter inlet hose with quick connect rubber cuffs
- Digital graphic controls
- (4) Industrial grade vibration isolators
- Installation guide / Operations manual

**Standard Filter Set:**

- Single Set Combined cartridge filtration system
  - Pre-Filter:
    - 85% efficient MERV 11 panel filter
  - HEPA Filter:
    - 99.97% efficient @ 0.3 micron
  - Activated Carbon Gas / Odor filter:
    - Provides broad spectrum gas/odor control
    - 100 % recyclable construction

# TECHNICAL DATA

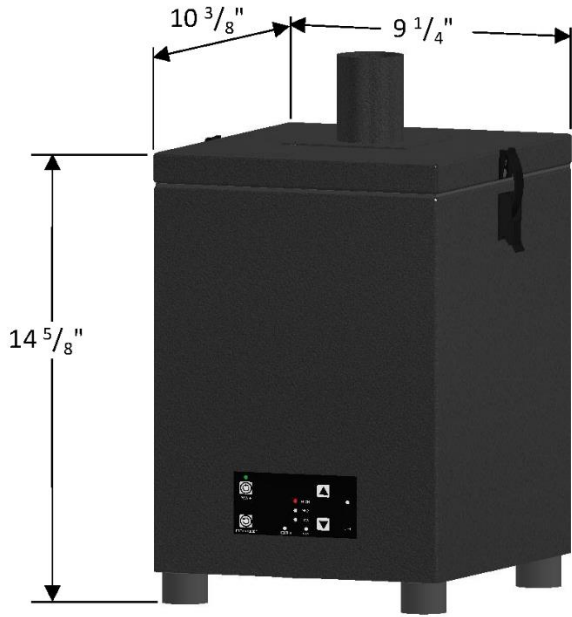

## Combined Cartridge Filter System (DT-1)

Pre-Filter  
HEPA Filter  
Activated Carbon Filter



- Programable via USB port pressure set points, blower speeds, and VOC detection
- High visibility LED display indicating blower speed, filter, and unit system status
- System Data logging: monitoring blower usage, filter service intervals accessed by USB port



# FUMEX ACCESSORIES

## Source Capture Hoods



**FA122**  
1"x4" Rectangular Hood



**FXA-127**  
Straight Nozzle

1"x4" Rectangular Hood



**FXA-125**  
3" Bell-Mouth Hood



**FA-125**  
2" Round Hood

## Source Capture Arms



**FXA-36-31**  
Stainless Steel Flexible Arm



**A-28-2**  
2" Diameter Articulating Arm

CONTACT: MURPHY ENTERPRISES OF AL INC  
<https://WWW.AIRPURIFIERSANDCLEANERS.COM>  
 TOLL FREE 800-701-2513  
 EMAIL: SUPPORT@AIRPURIFIERSANDCLEANERS.COM

